

Schottky Barrier Rectifier

SBLB16100CT

FEATURES

- High Surge Capacity.
- For Use In Low Voltage,High Frequency Inverters, Free Wheeling and Polarity Protection Applications.
- Metal Silicon Junction, Majority Carrier Conduction.
- High Current Capacity, Low Forward Voltage Drop.
- Guard Ring for Over Voltage Protection.



Lead-free

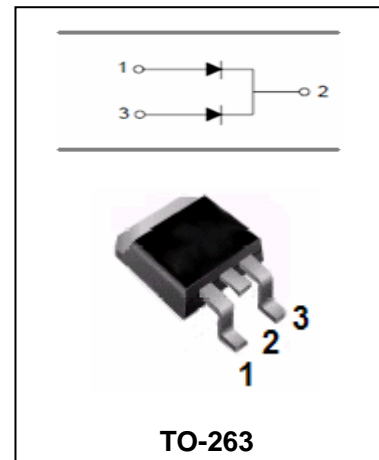

MAXIMUM RATING operating temperature range applies unless otherwise specified

Symbol	Parameter	Value	Unit
V_{RRM}	Repetitive Peak Reverse Voltage	100	V
V_{RMS}	RMS Voltage	70	V
V_{DC}	DC Blocking Voltage	100	V
$I_{F(AV)}$	Average Forward Rectified Current @ $T_A=100^{\circ}C$	16	A
I_{FSM}	Peak Forward Surge Current 8.3ms Single Half Sine-wave superimposed on rated load	250	A
$R_{\theta JC}$	Thermal Resistance (Note1)	2.0	$^{\circ}C/W$
$T_j T_{stg}$	Operating Junction and Storage Temperature Range	-55 to +150	$^{\circ}C$

Note:1. Thermal resistance from junction to case.



Schottky Barrier Rectifier

SBLB16100CT

ELECTRICAL CHARACTERISTICS @ Ta=25°C unless otherwise specified

Parameter	Symbol	Test conditions	Value	UNIT
Reverse Current	I_R	$V_{RM}=V_{RRM}, T_A=25^\circ C$ $V_{RM}=V_{RRM}, T_A=100^\circ C$	0.5 50	mA
Forward Voltage	V_F (Note1)	$I_F=8A$	0.85	V

Note:1. Pulse tere:300µs pulse width,1% duty cycle.

TYPICAL CHARACTERISTICS @ Ta=25°C unless otherwise specified

FIG.1 – PEAK FORWARD SURGE CURRENT

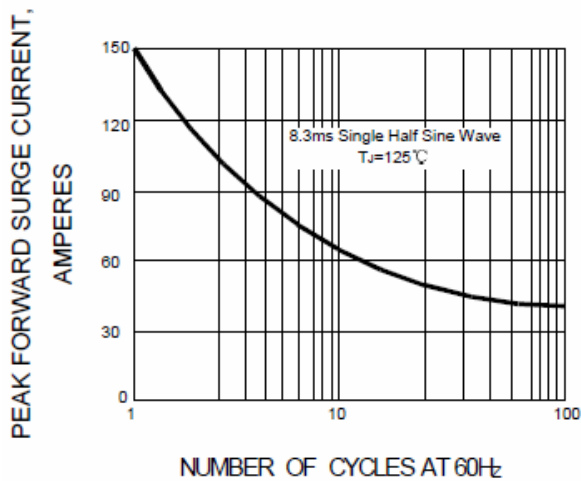
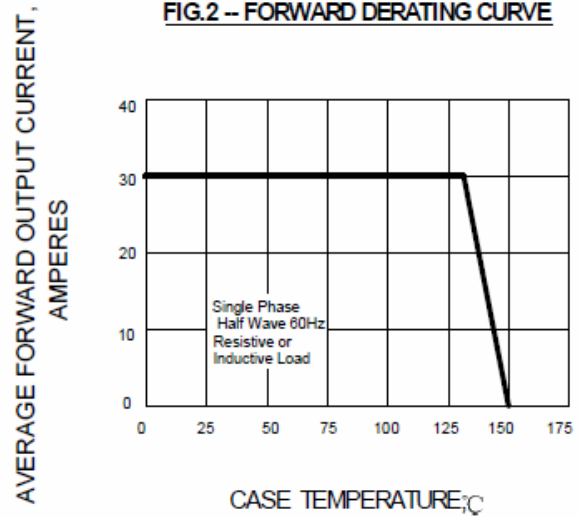

FIG.2 – FORWARD DERATING CURVE





Schottky Barrier Rectifier

SBLB16100CT

PACKAGE OUTLINE

Plastic surface mounted package

TO-263

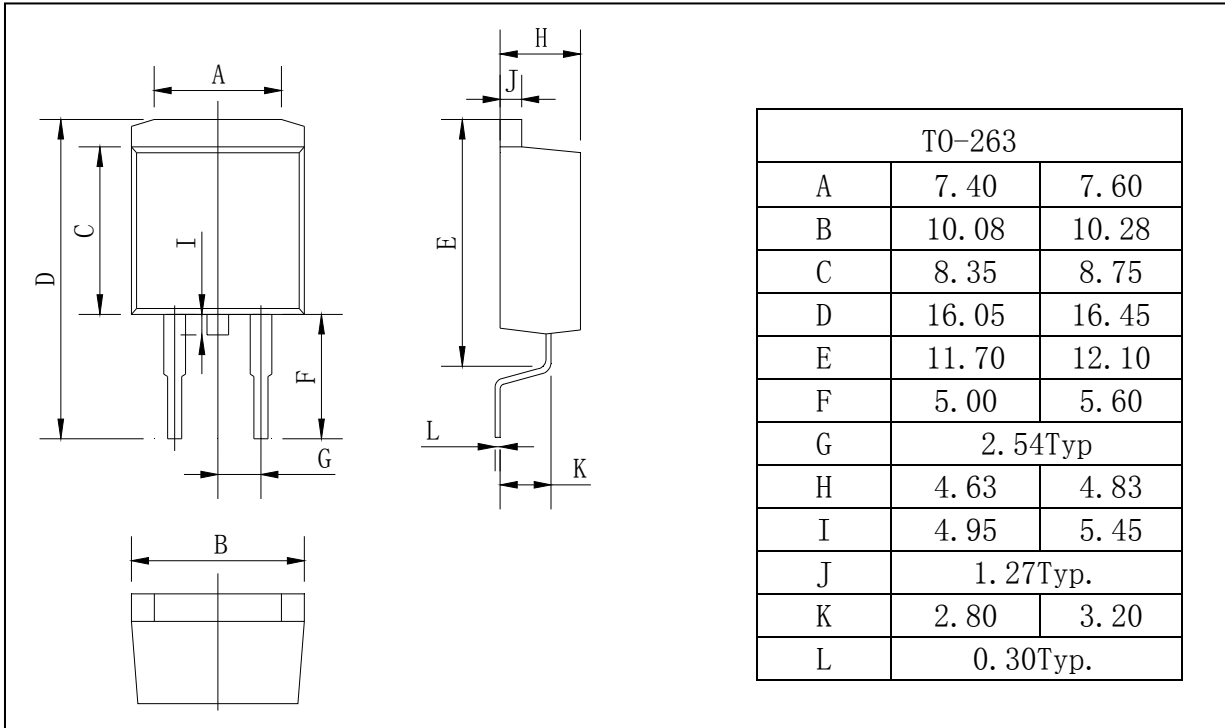

SOLDERING FOOTPRINT

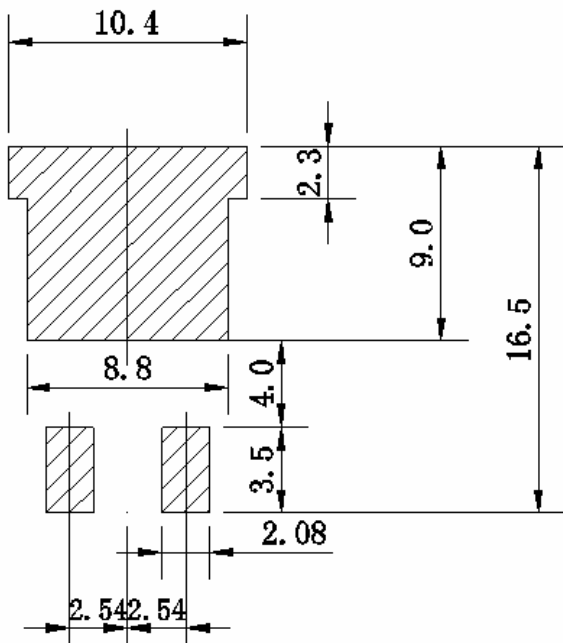

Unit:mm